



1						
ks	polotovár/norma	rozměr	material	povrch	svařovaný díl	
všeobecná norma ISO 2768 - mK	 CAD	datum	jméno	Název		měřítko
vypracoval		23.2.2012	Sklenarova	SEAT / SEDACKA J5S MAXI		1:5
kontrola						
norma				číslo-výkresu		hmotnost
				SVR00100AA		4524.30 g
změna	datum	jméno				ISO A3

1

2

3

4

A

B

C

D

E

F

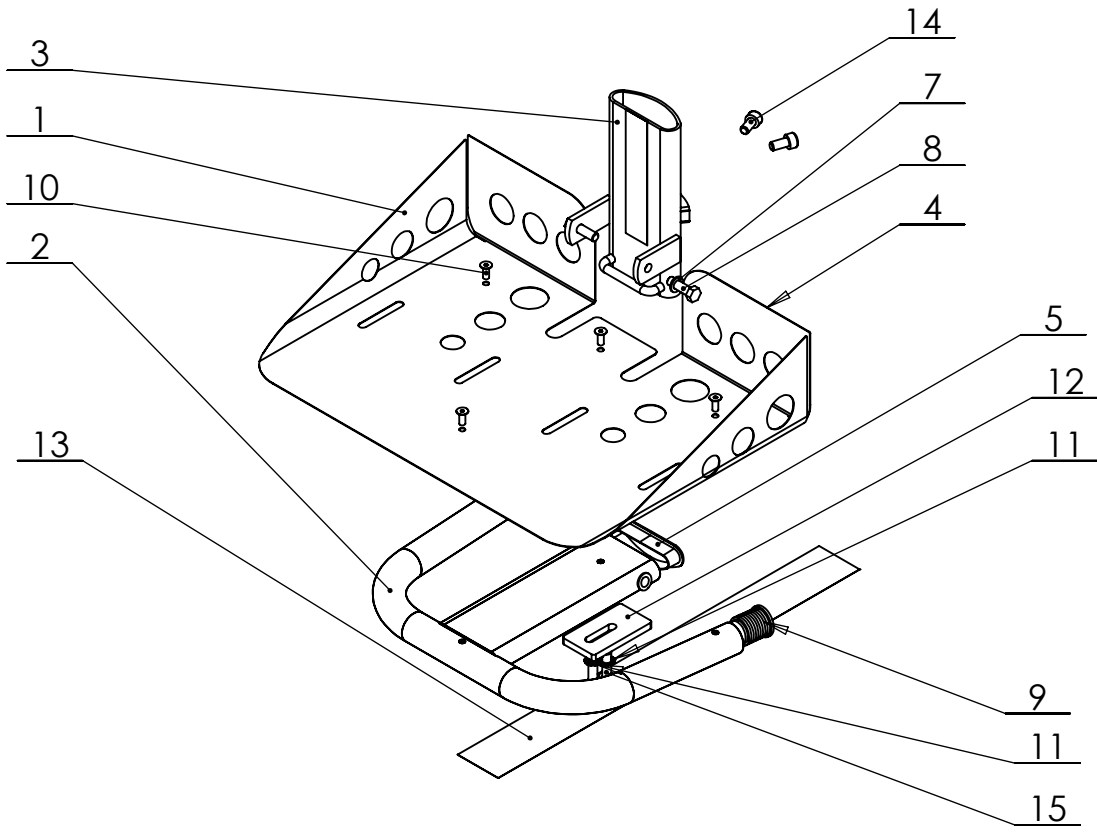

UNLESS OTHERWISE SPECIFIED:
 DIMENSIONS ARE IN MILLIMETERS
 SURFACE FINISH:
 TOLERANCES:
 LINEAR:
 ANGULAR:



	DATE	NAME
DRAWN	23.2.2012	Sklenarova
Norm		

TITLE:
**SEAT / SEDACKA-Def.B
 J5S MAXI**

SCALE
1:5

SIGNATURE	DATE	NAME



DWG NO.
SVR00102AA

ISO A4

WEIGHT:

SCALE:1:5

SHEET 2 OF 2

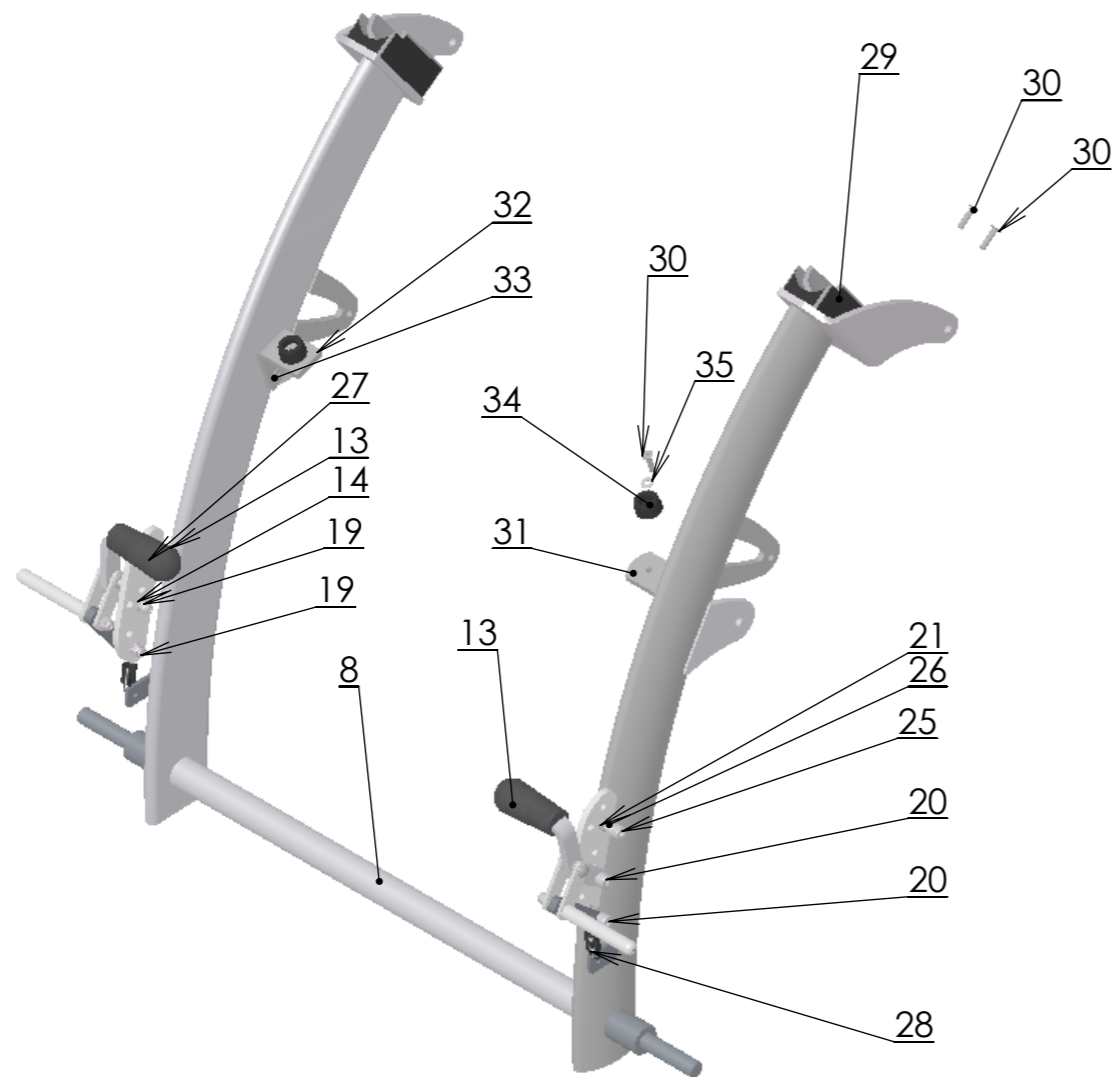

1					
ks	polotovár/norma	rozměr	material	povrch	svařovaný díl
všeobecná norma ISO 2768 - mK		datum	jméno	Název CHASSIS /PODVOZEK-Def.A J5S MAXI	měřítko 1:5
		vypracoval 23.2.2012	Sklenarova		
		kontrola			
		norma		číslo-výkresu	hmotnost
				SVR00104AA	1819.89 g
	změna	datum	jméno		ISO A3